



GR20T-ECT-0016ETP/0032ETP Series Digital Output Module User Guide



Industrial
Automation



Intelligent
Elevator



New Energy
Vehicle



Industrial
Robot



Rail
Transit



Data code PS00018056A00

Preface

Introduction

The GR20T-ECT-0016ETP/0032ETP is a transistor PNP module with 16/32 digital outputs. The module adapts to AM600 series products.

This guide describes the information, mechanical installation, electrical installation, and program commissioning of the product.

Standards compliance

The following table lists the certifications, directives, and standards that the product may comply with. For details about the acquired certificates, see the certification marks on the product nameplate.

Certification	Directive		Standard
CE Certification	EMC Directive	2014/30/EU	24 VDC products: EN 61131-2 220 VAC products: EN 61131-2 EN 61000-3-2 EN 61000-3-3
	LVD Directive	2014/35/EU	EN 61010-1 EN 61010-2-201
	RoHS Directive	2011/65/EU amended by (EU)2015/863	EN IEC 63000
UL/cUL Certification	-		UL 61010-1 UL 61010-2-201 CAN/CSA-C22.2 No. 61010-1 CSA C22.2 NO. 61010-2-201
KCC Certification	-		-
EAC Certification	-		-
UKCA Certification	Safety Regulations	Electrical Equipment (Safety) Regulations 2016	EN 61010-1 EN 61010-2-201
	EMC Regulations	Electromagnetic Compatibility Regulations 2016	24 VDC products: EN 61131-2 220 VAC products: EN 61131-2 EN 61000-3-2 EN 61000-3-3
	RoHS Regulations	Directive (RoHS) Regulations 2012	EN IEC 63000

More data

Name	Code	Description
AM600 Series Programmable Controller (NPN Output) User Guide	19010723	Introduces the information, electrical and mechanical design, communication connection, programming tools, operation and maintenance, indicators, MFK keys, and module connection of the product.
GR20T-ECT-0016ETP/0032ETP Series Digital Output Module User Guide (This guide)	PS00018056	Introduces the information, mechanical installation, electrical installation, programming, and commissioning of the product.

Revision history

Date	Version	Revision
January 2025	A00	Initial release.

Access to the guide

This guide is not delivered with the product. You can obtain the PDF version in the following ways

- Do keyword search under Service and Support at www.inovance.com.
- Scan the QR code on the product with your smart phone.
- Scan the QR code below to install My Inovance app, where you can search for and download user guides.



Warranty disclaimer

Inovance provides warranty service within the warranty period (as specified in your order) for any fault or damage that is not caused by improper operation of the user. You will be charged for any repair work after the warranty period expires.

Within the warranty period, maintenance fee will be charged for the following damage:

- Damage caused by operations not following the instructions in the user guide
- Damage caused by fire, flood, or unusual voltage
- Damage caused by unintended use of the product
- Damage caused by use beyond the specified scope of application of the product
- Damage or secondary damage caused by force majeure (natural disaster, earthquake, and lightning strike)

The maintenance is charged according to the latest Price List of Inovance. If otherwise agreed upon, the terms and conditions in the agreement shall prevail.

For details, see Product Warranty Card.

1 Product Information

1.1 Model and Nameplate

Model

G
R
20
T
-ECT-0016
E
TP

①
②
③
④
⑤
⑥
⑦
⑧

<p>① Product Family G: Inovance controller general-purpose module</p>	<p>⑤ Communication Protocol ECT: EtherCAT</p>
<p>② Product Type R: Remote module</p>	<p>⑥ Number of Output Channels 0016: 16 output channels 0032: 32 output channels</p>
<p>③ Series 20: 20 series</p>	<p>⑦ Product Type E: Logic I/O expansion module</p>
<p>④ Product Form T: Horizontal</p>	<p>⑧ Function Type TN: Transistor output (sink mode) TP: Transistor output (source mode)</p>

Nameplate

- GR20T-ECT-0016ETP

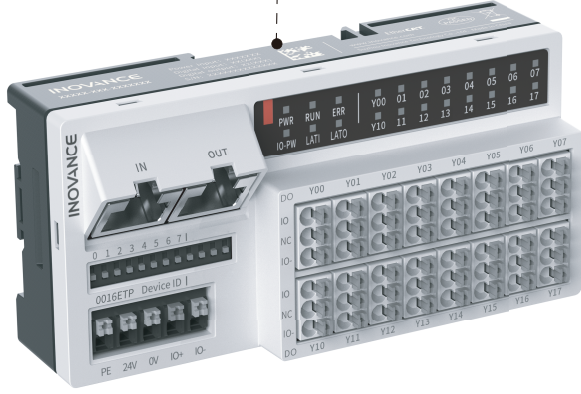
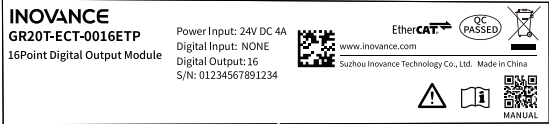

- GR20T-ECT-0032ETP







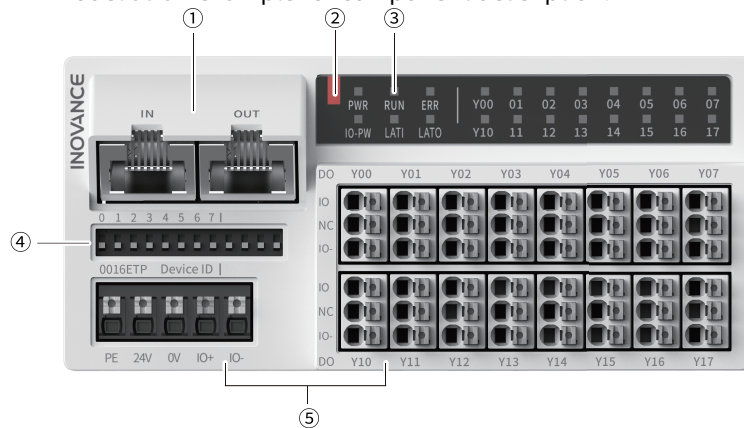

The data for ordering the product is shown in the following table.

Model	Description	Material Code	Applicable Model
GR20T-ECT-0016ETP	GR20T series 16-channel digital PNP transistor output module	01440861	AM600 series
GR20T-ECT-0032ETP	GR20T series 32-channel digital PNP transistor output module	01440904	

1.2 Components

The GR20T-ECT-0016ETP and GR20T-ECT-0032ETP models share the same components. Take the GR20T-ECT-0016ETP model as an example for component description.



No.	Component	Description	
①	EtherCAT communication interface	IN	EtherCAT communication input The IN interface supports EtherCAT communication data input with connection to PLC, communication interface module, or the upstream EtherCAT slave.
		OUT	EtherCAT communication output The OUT interface supports EtherCAT communication data output with connection to the downstream EtherCAT slave.
②	Color identification	 Red: Digital output	 Orange: Analog output
		 Gray: Digital input	 Green: Analog input
		 White: Communication	 Blue: Other modules

No.	Component	Description	
③	Signal indicator	PWR	System power supply indicator The indicator is solid ON for power-on and OFF for power-off (24 VDC).
		RUN	Running state indicator The ECT communication status indicator indicates status of the ECT simple slave. <ul style="list-style-type: none"> • OFF: The ECT module is in the initial (INIT) state. • Flashing: The ECT module is in the pre-operational (PREOP) state. • Single flashing: The ECT module is in the safe-operational (SafeOP) state. • Solid ON: The ECT module is in the operational (OP) state. • Double flashing: The ECT module is in the bootstrap state.
		ERR	Fault indicator The indicator is ON when the module is faulty.
		IO-PW	I/O power indicator The indicator is solid ON for power-on and OFF for power-off (24 VDC).
		LATI	ECT_IN network port indicator <ul style="list-style-type: none"> • OFF: No connection • Flashing: Connected with data being exchanged • Solid ON: Connected with no data exchange
		LATO	ECT_OUT network port indicator <ul style="list-style-type: none"> • OFF: No connection • Flashing: Connected with data being exchanged • Solid ON: Connected with no data exchange
		Y00 to Y07 Y10 to Y17	Signal indicator of DO0 to DO7 Signal indicator of DO8 to DO15 The indicator turns green when the DO signal is active.
④	DIP switch	Device ID (0 to 7)	Slave address DIP switch (with 8 positions) Toggling up a position to turn it ON and toggling down a position to turn it OFF. For example, when position 0 is toggled up to ON, the corresponding Device ID is 1.
⑤	User terminal	For details, see “3.2 Terminal Definition” on page 21	

Note

- Flashing: The indicator is on for 200ms and off for 200ms, repeating this cycle.
 - Single flashing: The indicator is on for 200ms and off for 1000ms, repeating this cycle.
 - Double flashing: The indicator is on for 200ms, off for 200ms, on for 200ms, and off for 1s, repeating this cycle.
-

1.3 Technical Specifications

General specifications

Item	GR20T-ECT-0016ETP	GR20T-ECT-0032ETP
IP rating	IP20	
Dimensions (W x H x D)	110 mm x 50 mm x 35.9 mm	160 mm x 50 mm x 35.9 mm
Weight	About 123.6 g	About 191.1 g

Power supply specifications

Item	Specification
Rated voltage of US power supply	24 VDC (20.4 VDC to 28.8 VDC)
Maximum current of US power supply	1 A (@24 V)
Rated voltage of UA power supply	24 VDC (20.4 VDC to 28.8 VDC)
Output current of UA power supply	<ul style="list-style-type: none"> • GR20T-ECT-0016ETP: 4 A (Max. 24 V) • GR20T-ECT-0032ETP: 8 A (Max. 24 V)
Reversed polarity protection of US system power supply	Supported
Short circuit protection of US system power supply	Supported
Reversed polarity protection of UA I/O power supply	Supported
Short circuit protection of UA I/O power supply	Supported
DO overcurrent protection	Supported
DO short circuit protection	Supported
DO overcurrent diagnosis	The overcurrent status of all 16 DO channels is indicated through a diagnostic signal.
I/O power supply diagnosis	Supports identifying an abnormal I/O power failure

EtherCAT specifications

Item	Specification
Communication protocol	EtherCAT protocol (SDO not supported)
Communication speed	100 Mbit/s (100Base-TX)
Work mode	Full duplex
Transmission medium	Shielded cables of Cat 5e or higher
Transmission distance	100 m
Interface type	RJ45

Output specifications

Item	GR20T-ECT-0016ETP	GR20T-ECT-0032ETP
Output type	Digital output, high side transistor output	
Output mode	PNP (source mode)	
Maximum number of output channels	16	32
Output voltage	24 VDC (20.4 VDC to 28.8 VDC)	
Output load (resistive load)	0.5 A/channel; 1 A /4 channels; 4 A/module	0.5 A/channel; 1 A /4 channels; 8 A/module
Output load (inductive load)	7.2 W/channel; 12 W/module	7.2 W/channel; 24 W/module
Output load (lamp load)	5 W/channel; 9 W/module	5 W/channel; 18 W/module
Hardware response time upon ON/OFF	100μs(Max.)/100μs(Max.)	
Leakage current upon OFF	10 μA	
Switching frequency	Resistive load: 100 Hz; inductive load: 0.5 Hz; lamp load: 10 Hz	
Isolation	Isolated	
Output indicator	The output indicator turns ON when the DO circuit is in the active state.	
Output derating (without dust cover)	<ul style="list-style-type: none"> Take resistive load as an example, the module works at full load at 50°C (with the output current of all simultaneously ON output channels not exceeding 4 A). The module works at 50% of full load at 55°C (with the output current of all simultaneously ON output channels not exceeding 2 A). 	<ul style="list-style-type: none"> Take resistive load as an example, the module works at full load at 45°C (with the output current of all simultaneously ON output channels not exceeding 8 A). The module works at 50% of full load at 55°C (with the output current of all simultaneously ON output channels not exceeding 4 A).
Output derating (with dust cover)	<ul style="list-style-type: none"> Take resistive load as an example, the module works at full load at 50°C (with the output current of all simultaneously ON output channels not exceeding 4 A). The module works at 50% of full load at 55°C (with the output current of all simultaneously ON output channels not exceeding 2 A). 	<ul style="list-style-type: none"> Take resistive load as an example, the module works at full load at 40°C (with the output current of all simultaneously ON output channels not exceeding 8 A). The module works at 50% of full load at 55°C (with the output current of all simultaneously ON output channels not exceeding 4 A).

Software specifications

Item	Specification
Output PDO data volume	<ul style="list-style-type: none"> GR20T-ECT-0016ETP: 8 bytes GR20T-ECT-0032ETP: 16 bytes
ECT simple slave	Meets ECT certification requirements of conformance
Basic ECT function	Supports the ECT ring-type networking
Output preset value	Supports configuring the output preset value through PDO.
Output maintaining	Supports configuring the output maintaining function through PDO.
Output indicator management	Supports configuring the output indicator to become ON upon output.
Station number configuration	Supports configuring the station number from 1 to 255 through the DIP switch. This method is enabled when at least one of the switch positions is set to non-zero.
	Supports configuring the station number from 0 to 65535 through the software tool. This method is enabled when all switch positions are set to 0.

1.4 Environmental Specifications

Item	Specification
Operating environment	Free from conductive dust, conductive fibers, explosive dust, flammable gases, water mist/greasy dirt, corrosive dusts/gases, strong vibration, and repetitive shock
Altitude	≤ 2000 m
Pollution degree	2
Noise immunity	2 kV on power supply cable (compliant with IEC 61000-4-4)
Overvoltage category	I
EMC immunity level	Zone B, IEC61131-2
ESD protection level	Contact discharge +/-6 kV, air discharge +/-8 kV
Vibration resistance	<ul style="list-style-type: none"> Application scenario: The module passes the sinusoidal vibration test according to IEC60068-2-6. (Test conditions: 3.5 mm amplitude at 5 Hz to 8.4 Hz; 1 g gravitational acceleration at 8.4 Hz to 200 Hz; 10 cycles per axial direction) Transport scenario: The module passes the random vibration test according to IEC 60068-2-64. (Test conditions: 0.01g²/Hz at 5 Hz to 100 Hz; 0.001g²/Hz at 200 Hz, 1.14g Grms)
Shock resistance	Application/Transportation scenario: The module passes the test according to IEC60068-2-27. (Test conditions: 15 g peak gravitational acceleration; 11ms pulse width; 18 times in X/Y/Z directions)
Operating temperature/humidity	<ul style="list-style-type: none"> Temperature: -20°C to +55°C Relative humidity: 10% to 90% RH, non-condensing Note: Install a fan or air conditioner in the direction of the ventilation holes when the operating temperature is greater than the maximum allowable temperature.
Storage temperature/humidity	<ul style="list-style-type: none"> Temperature: -40°C to +70°C Relative humidity: < 90% RH, non-condensing

2 Mechanical Installation

2.1 Installation Precautions

- Before installing or removing the module, ensure that the module is powered off.
- Do not hot swap the modules. Otherwise, the modules may be damaged by overcurrent or overvoltage, and the communication interface module or PLC may be subject to restart, user data loss, or corruption.
- Prevent the enclosure or terminals of the module from dropping or being impacted to avoid damage to the module.

2.2 Installation Position

Installation limits

The outputs of the GR20T-ECT-0016ETP/0032ETP module are derated based on the actual number of I/O channels (taking the configuration without a dust cover as an example).

GR20T-ECT-0016ETP

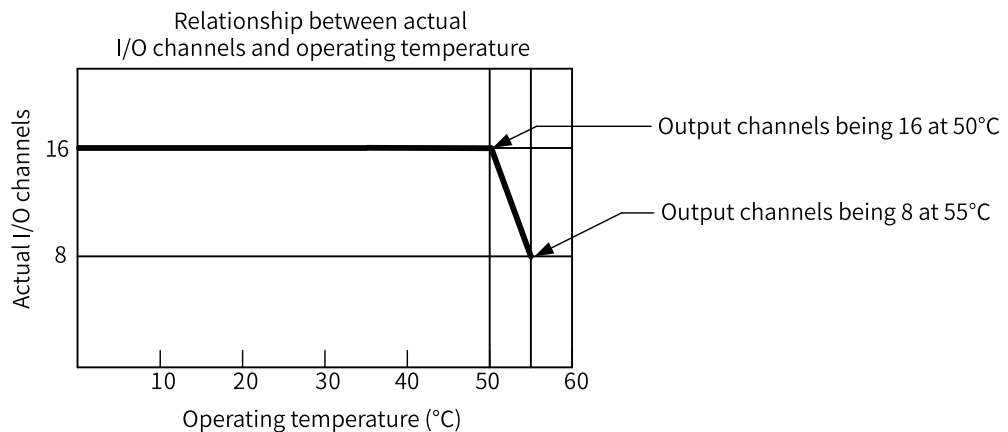

GR20T-ECT-0032ETP

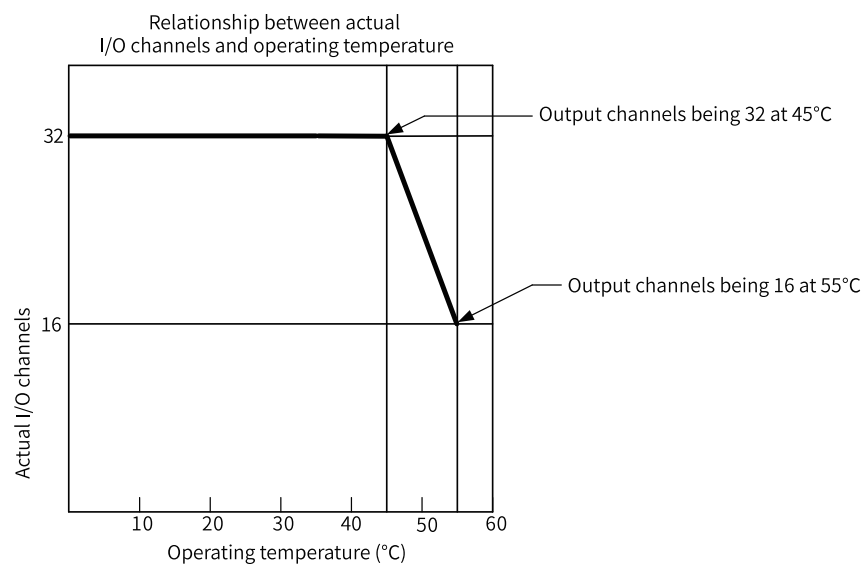

Optimal installation position

It is recommended to install the product horizontally. To ensure normal ventilation and heat dissipation and allow sufficient wiring space, reserve enough clearance (in mm) around the product, as shown in the following figure. Different installation modes require different operating

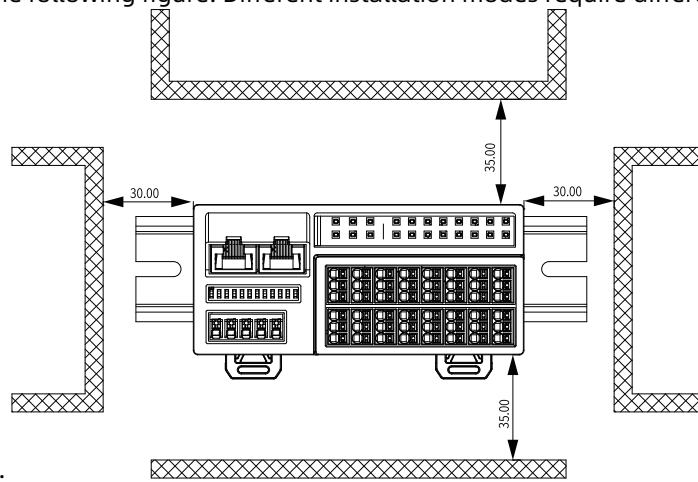

temperatures.

Note

If there is a high-temperature heat source (heater, transformer, large resistor, etc.) in vicinity of the product, keep the product away from the heat source by at least 100 mm.

Other installation positions

Other installation positions are shown below. The same clearances as the optimal installation position are also required.

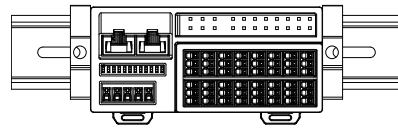

Horizontal DI rail + Horizontal module

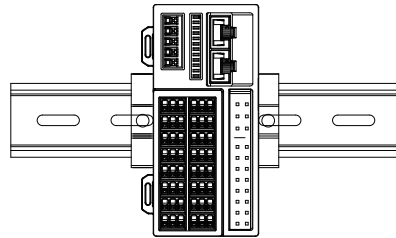

Horizontal DI rail + Vertical module

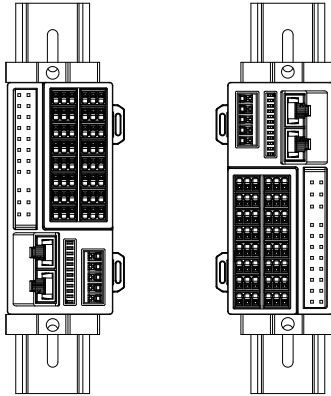

Vertical DI rail + Vertical module

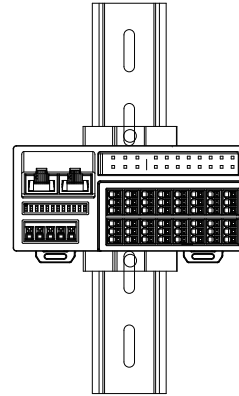

Vertical DI rail + Horizontal module

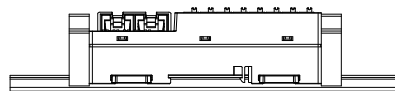

Bottom of the electric cabinet

Note

The preceding mounting options allow the installation of external screws.

2.3 Installation Dimensions

The module installation dimensions (in mm) are shown in the figure below.

- GR20T-ECT-0016ETP
 - Outline dimensions of the module

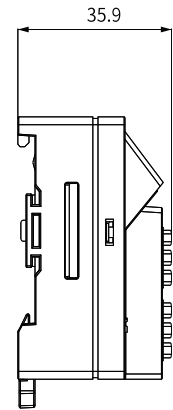
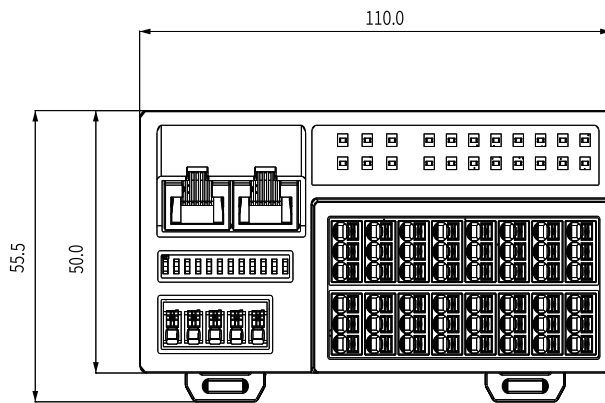
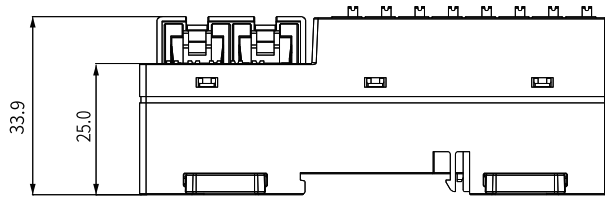

- Installation dimensions of external screws

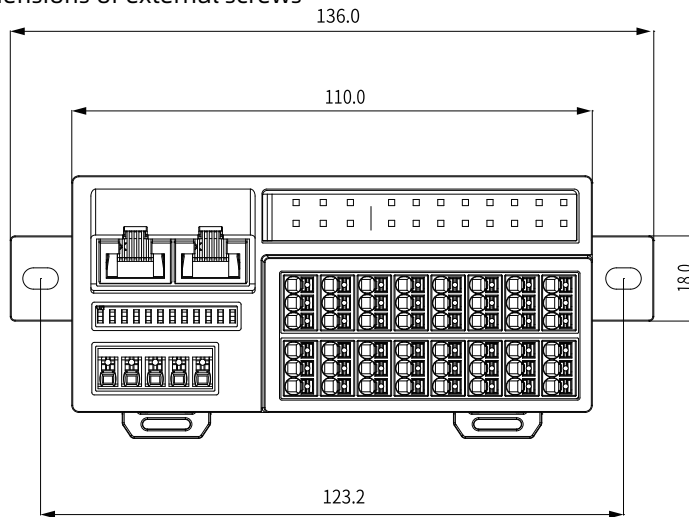

- GR20T-ECT-0032ETP
 - Outline dimensions of the module

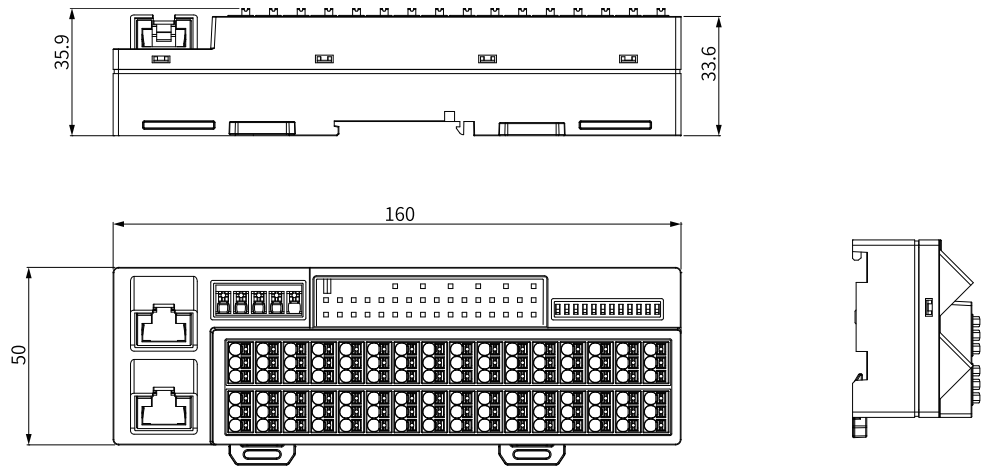

- Installation dimensions of external screws

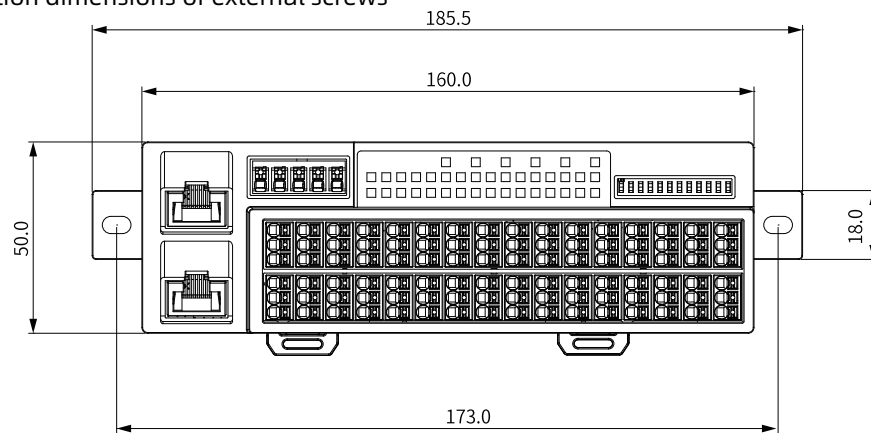

2.4 Installation Method

The GR20T-ECT-0016ETP and GR20T-ECT-0032ETP models share the same structure. Take the GR20T-ECT-0016ETP model as an example for installation instructions.

Module installation

The module can be installed in three modes including horizontal module mounting with horizontal DIN rail, vertical module mounting with horizontal DIN rail, and screw mounting.

The DIN rail used for installation shall comply with IEC 60715 (width: 35 mm, thickness: 1 mm). The dimensions (unit: mm) are shown below.

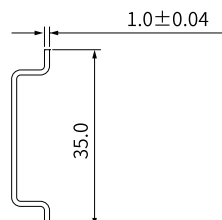

 **Caution**

The module is installed onto a DIN rail in conformity with IEC 60715 (thickness: 1.0 mm). If the thickness of the DIN rail is not as required, the product will not fit in place and function properly as the snap-fit joint does not work.

- **Horizontal installation with a horizontal DIN rail**

Hang the slot at the top of the module on the rail, rotate the module, and press down the bottom until you hear a click of the DIN rail snap-fit joint rebounding, as shown in the following figure.

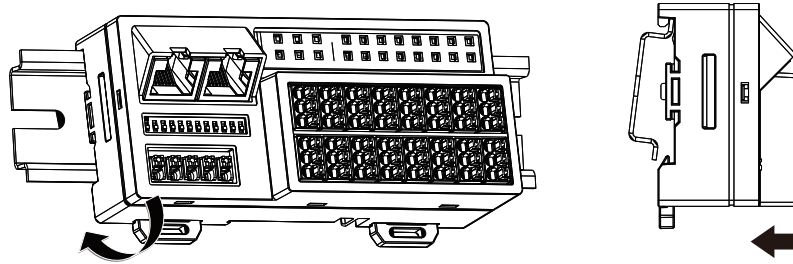

After the module is installed, the DIN rail snap-fit joint will automatically move upwards to lock the module to the rail. If the snap-fit joint does not move upwards, press the bottom of the snap-fit joint upwards to lock the module, as shown in the following figure.

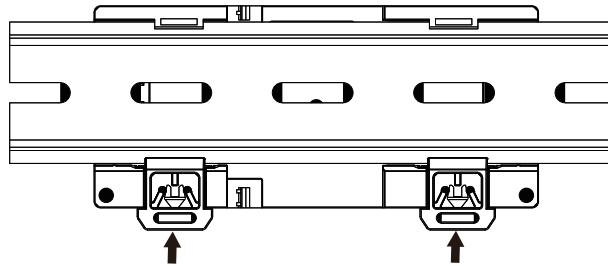

- **Vertical installation with a horizontal DIN rail**

1. Hang the slot at the upper part of the module on the rail, rotate the module, and press down the bottom until you hear a click of the DIN rail snap-fit joint rebounding, as shown in the following figure.

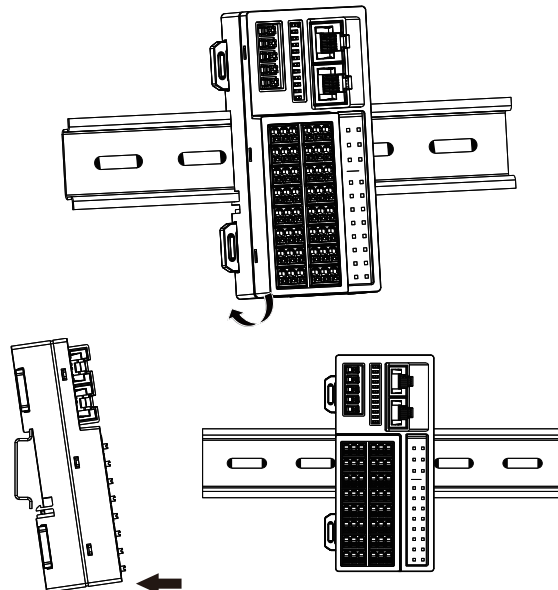

2. Install and secure the side plates on guide rails on both sides of the module properly, as shown in the following figure.

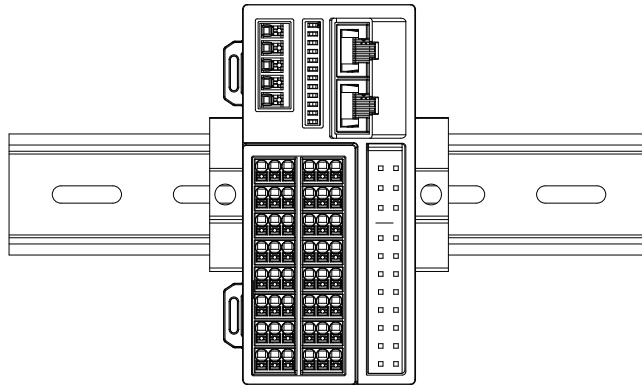

Note

- After the module is installed in place, the snap-fit joint will automatically rebound to lock the module to the rail.
- Ensure that the network port faces up when the module is installed vertically onto the horizontal DIN rail.

• Installation with screws

1. Take out the snap-fit joints (standard by default) from the accessory kit, and push them into the bottom of the module in the direction indicated by the following figure.

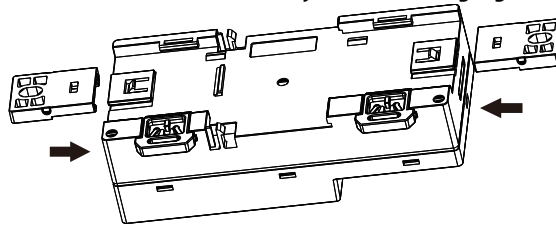

2. Push the snap-fit joints onto the module until you hear a click of the joint rebounding, as shown in the following figure.

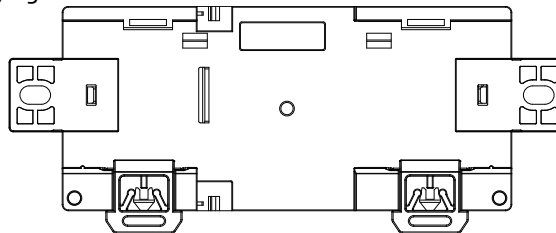

3. Secure the snap-fit joints with M4 screws, as shown in the following figure.

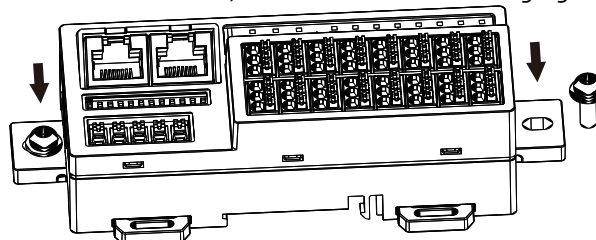

Module removal

- Removal for horizontal installation with a horizontal DIN rail

1. Pry the DIN snap-fit joint downwards with a disassembly tool such as screwdriver to release the joint, as shown in the following figure.

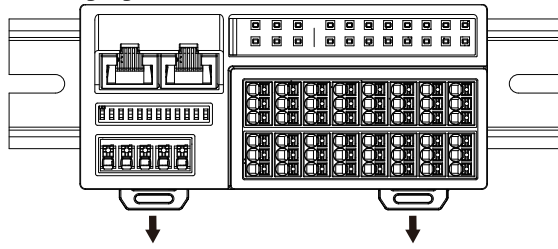

The following figure indicates that the snap-fit joint has been released.

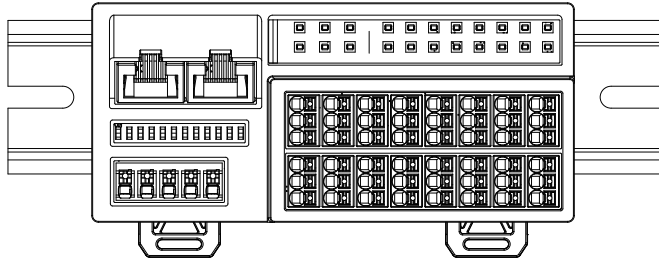

2. Rotate and remove the module out of the guide rail, as shown in the following figure.

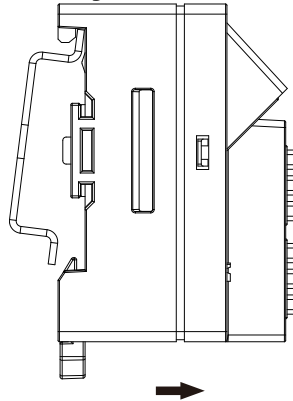

- **Removal for vertical installation with a horizontal DIN rail**

1. Remove all cables from the module.
2. Push the module upwards in the direction indicated by the arrow, as shown in the following figure.

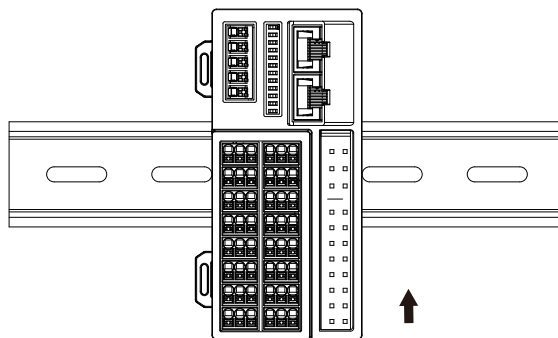

3. When pushing the module upwards, move the top of the module away from the guide rail in the direction indicated by the arrow, as shown in the following figure.

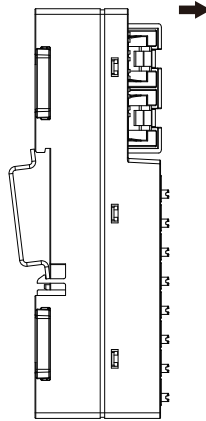

4. Rotate and remove the module out of the guide rail, as shown in the following figure.

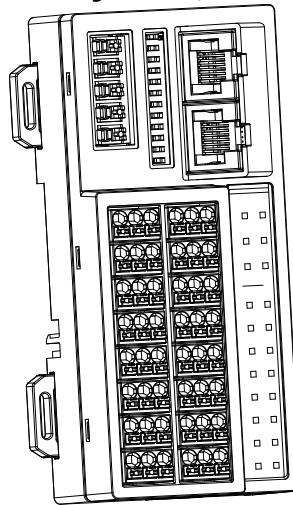

- **Removal for installation with screws**

1. Remove the two M4 screws on both sides of the module using a screwdriver, as shown in the following figure.

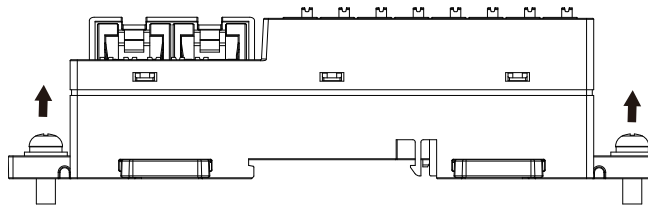

2. Remove the snap-fit joints manually, as shown in the following figure.

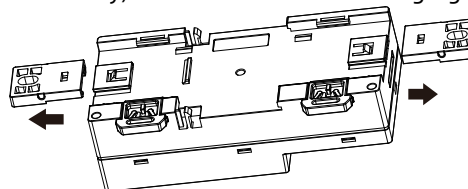

The module has been removed successfully, as shown in the following figure.

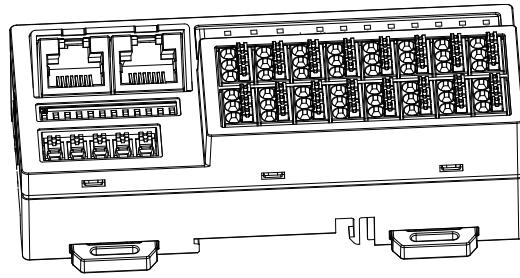

2.5 Dust Cover Installation (Optional)

The dust cover is available. The order data is shown in the following table.

Model	Description	Material Code	Applicable Model
GR20T-ECT-16P-FCZ	GR20T-ECT-16P-FCZ-GR20T series dust cover	01480056	GR20T-ECT-0016ETP
GR20T-ECT-32P-FCZ	GR20T-ECT-32P-FCZ-GR20T series dust cover	01480057	GR20T-ECT-0032ETP

The dust cover is designed to prevent dust, splashing, and impact. It is made of transparent PC, which allows you to observe the running state of the module at any time. It is suitable for non-standard equipment and intelligent production lines.

Dust cover dimensions

- GR20T-ECT-16P-FCZ

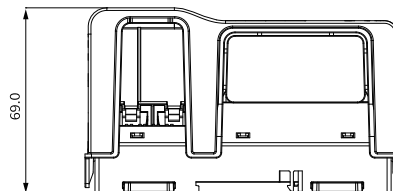
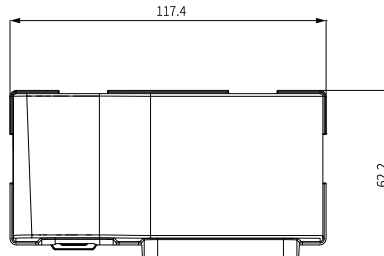

- GR20T-ECT-32P-FCZ

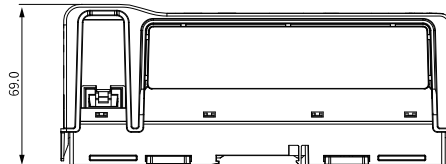
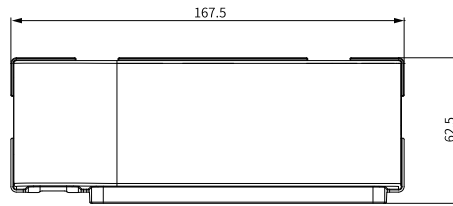

The GR20T-ECT-0016ETP and GR20T-ECT-0032ETP models share the same dust cover structure. Take the GR20T-ECT-0016ETP model as an example for dust cover installation instructions.

Pre-installation instructions

- The dust cover with a retaining plate (by default) at the cable outlet can be used together with I/O cables of diameters no more than 0.35mm² to connect the module, as shown in the following figure.

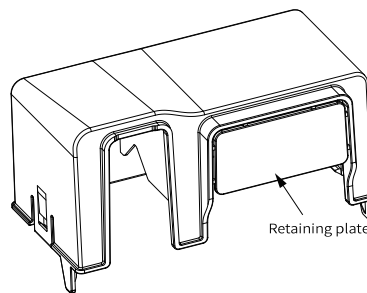

- The dust cover without retaining plate (which can be removed manually or with a tool) can be used together with I/O cables of diameters no more than 0.75 mm² to connect the module, as shown in the following figure.

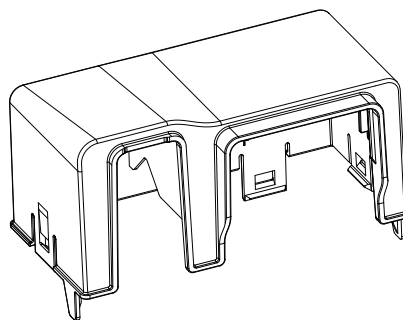

Installation procedure

1. Align the dust cover with the module and route the network cable and I/O cable through the cable slots, as shown in the following figure.

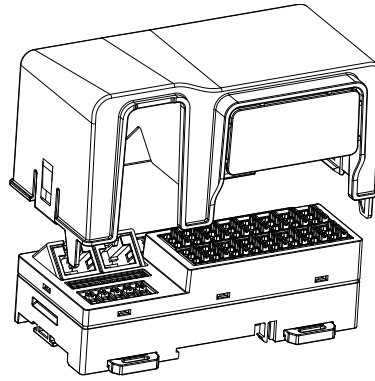

2. Press on both sides of the dust cover in the direction indicated in the following figure until you hear a click.

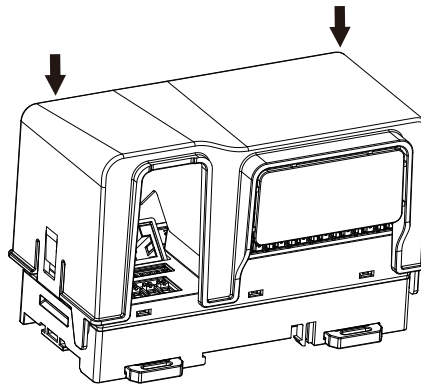

Dust cover removal

Rotate the dust cover in the direction indicated in the following figure to release the two snap-fit joints from the slot.

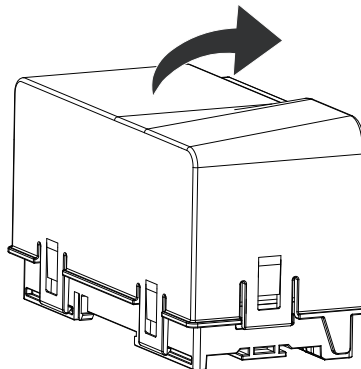

3 Electrical Installation

3.1 Cable Selection

The cable lug and cable diameter included in the following table are only for reference.

Material Name	Cable Diameter		KST		Suzhou Yuanli	
	mm ²	AWG	Model	Crimping Tool	Model	Crimping Tool
Tubular lug	0.3	22	E0308	KST2000L	0308	YAC-5
	0.5	20	E0508		0508	
	0.75 ^[1]	18	E7508		7508	

If other types of tubular lug are used, crimp the lug to the cables according to the shape and dimension requirements shown in the figure below.

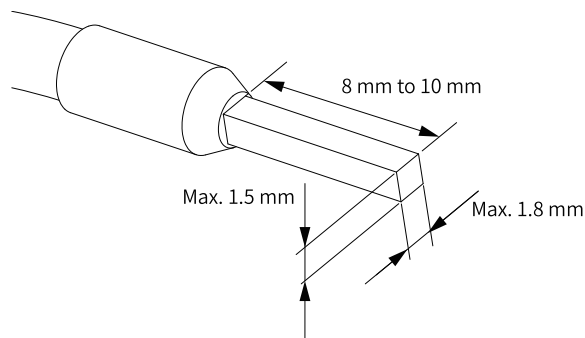

[1]: For 18 AWG cables with a diameter of 0.75 mm², it is recommended to use naked cable connectors rather than tubular lugs.

3.2 Terminal Definition

- GR20T-ECT-0016ETP

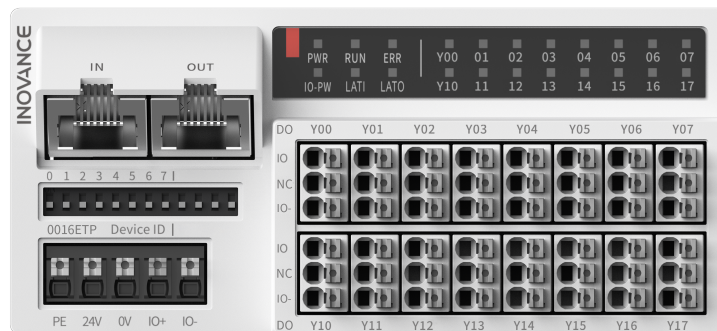

Signal	Interface	Interface	Signal
DO0	Y00	Y10	DO8
DO1	Y01	Y11	DO9
DO2	Y02	Y12	DO10
DO3	Y03	Y13	DO11
DO4	Y04	Y14	DO12
DO5	Y05	Y15	DO13
DO6	Y06	Y16	DO14
DO7	Y07	Y17	DO15

Refer to the following table for the correspondence between power supply terminals and signal indicators.

Power Supply Terminal	Description	Signal Indicator
PE	Protective grounding	-
24V	US system power supply +	PWR
0V	US system power supply -	
IO+	UA field power supply +	IO-PW
IO-	UA field power supply -	

● GR20T-ECT-0032ETP

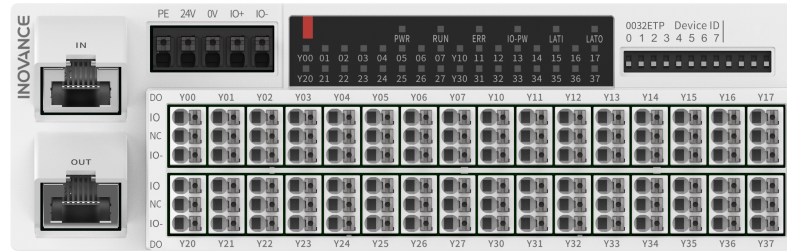

Signal	Interface	Interface	Signal
DO0	Y00	Y20	DO16
DO1	Y01	Y21	DO17
DO2	Y02	Y22	DO18
DO3	Y03	Y23	DO19
DO4	Y04	Y24	DO20
DO5	Y05	Y25	DO21
DO6	Y06	Y26	DO22
DO7	Y07	Y27	DO23
DO8	Y10	Y30	DO24
DO9	Y11	Y31	DO25
DO10	Y12	Y32	DO26
DO11	Y13	Y33	DO27
DO12	Y14	Y34	DO28
DO13	Y15	Y35	DO29
DO14	Y16	Y36	DO30
DO15	Y17	Y37	DO31

Refer to the following table for the correspondence between power supply terminals and signal indicators.

Power Supply Terminal	Description	Signal Indicator
PE	Protective grounding	-
24V	US system power supply +	PWR
0V	US system power supply -	
IO+	UA field power supply +	IO-PW
IO-	UA field power supply -	

3.3 Terminal Wiring

Precautions

- Do not bundle the expansion cable together with power cables (with high voltage and large current) that produce strong interference signals; otherwise, the expansion cable may be influenced by noise, surge, or induction. Separate it from other cables and avoid cabling in parallel.
- Use recommended cables and adapter boards for connection. It is recommended that shielded cables be used as expansion cables to enhance anti-interference capacity.
- Apply single-point grounding for the shielding of shielded cable and solder sealed cable.

Circuit block diagram and wiring diagram

- **GR20T-ECT-0016ETP**

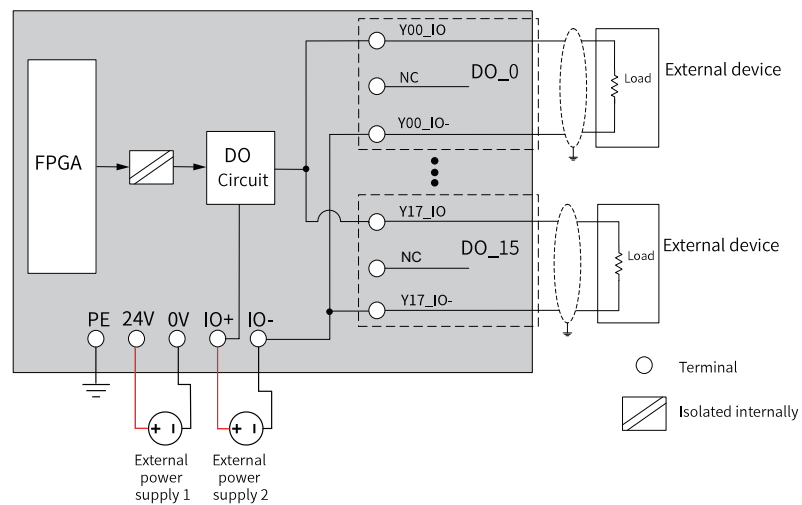

- **GR20T-ECT-0032ETP**

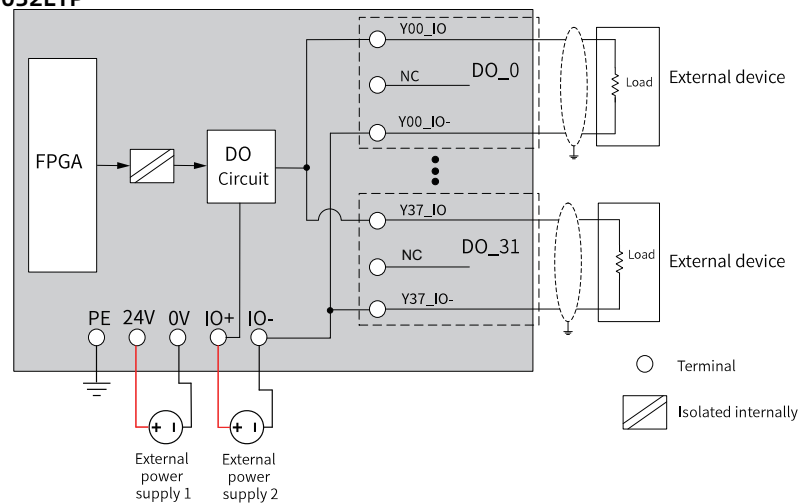

4 Program Commissioning

The following is an example where AM600 master is used as the primary control module.

1. In the "Devices" pane, double-click "Network Configuration". Click the AM600 PLC figure and check "EtherCAT Master" to enable the PLC as an EtherCAT master.

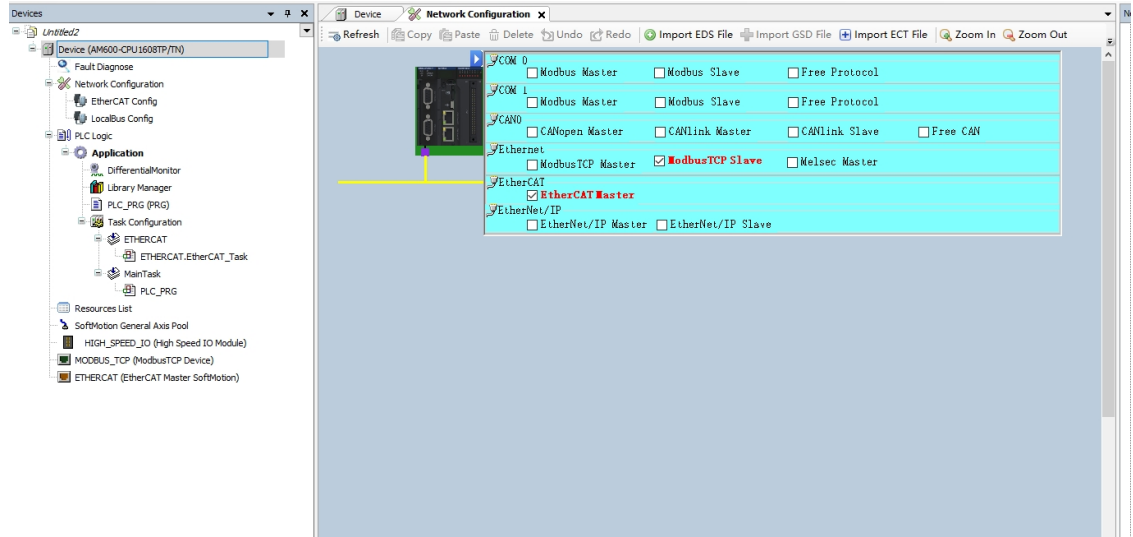

2. In the "Devices" pane, right-click "ETHERCAT(EtherCAT Master SoftMotion)", select "Scan For Devices", and add the scanned device.
 - a. Click "Scan For Devices". After the module is successfully scanned, click "Copy all to device".
 - b. Set the slave alias.

Slave alias can be set through the DIP switch and software.

 - When the DIP switch is at non-zero position, the slave alias set by the DIP switch is used. Otherwise, the slave alias set by the software is used.
 - To set slave alias through the software, fill in the alias address in "Write Alias Address". Then, click "Assign Address" and "OK". Power on the slave again and scan the device.

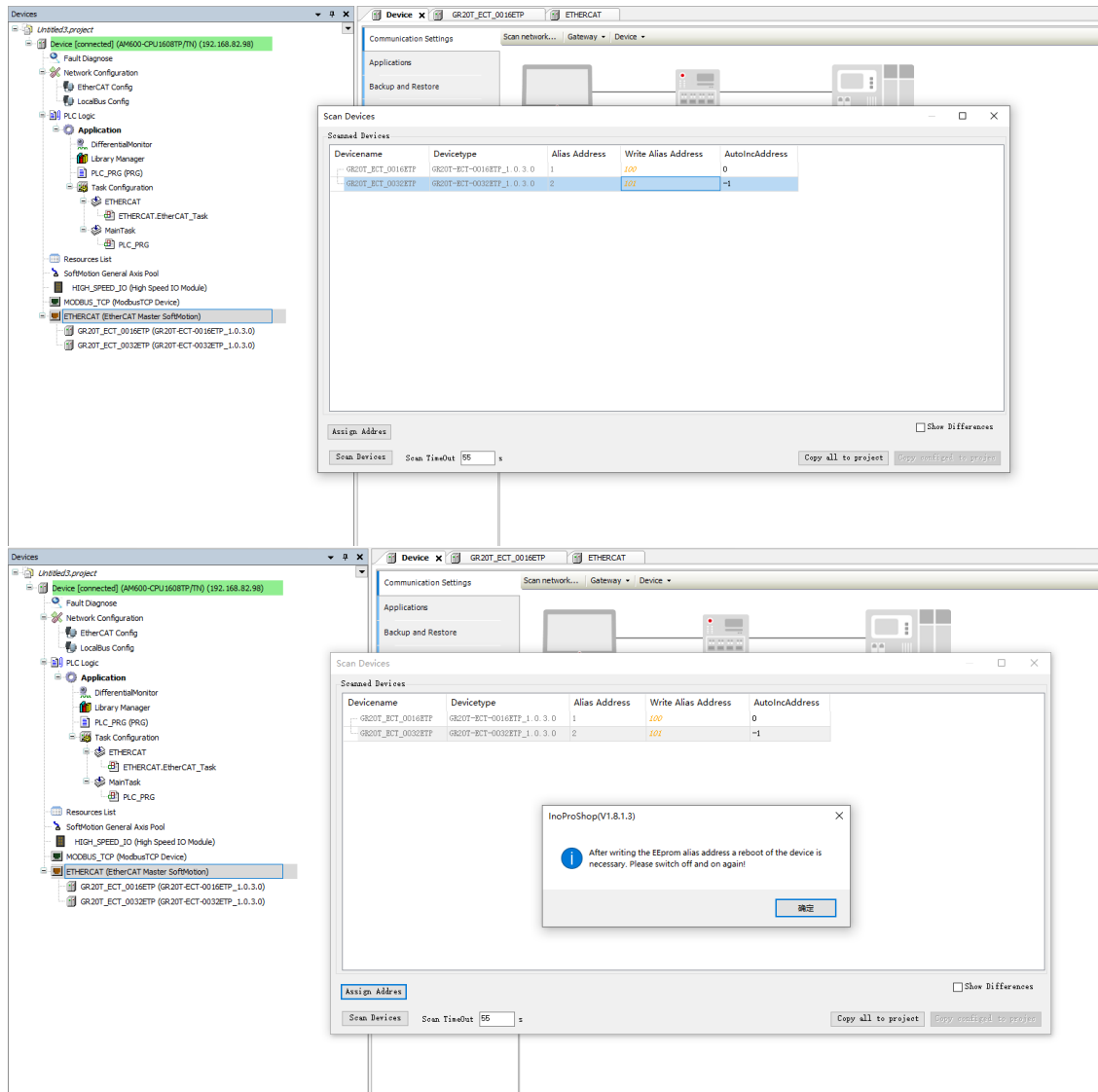

3. After the module is added successfully, the slave is configured in "Mixed mode" by default. To configure a slave in "Alias mode", double-click "ETHERCAT (EtherCAT Master SoftMotion)" in the "Devices" pane. Then, click "Overview" on the "ETHERCAT" tab to select the "Alias mode". Fill in the alias address for each slave and click  in the toolbar, as shown in the following figure.

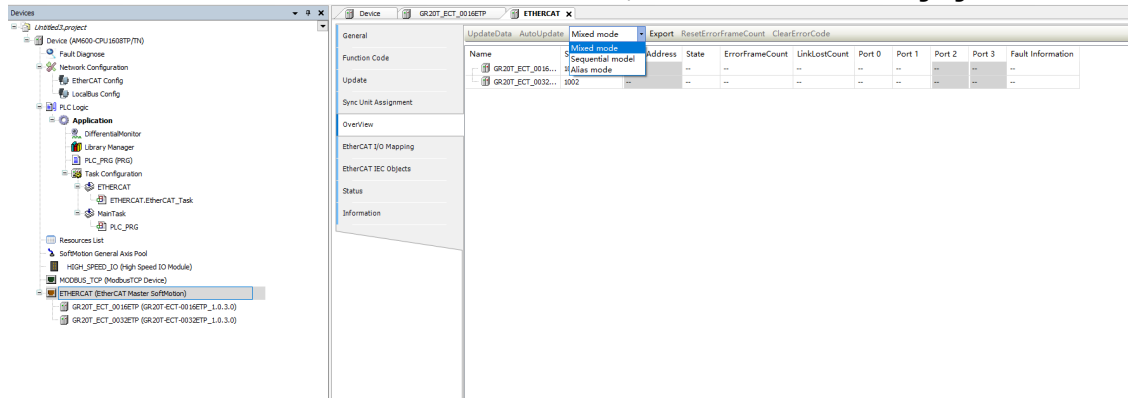

4. Click  to start the module, as shown in the following figure.

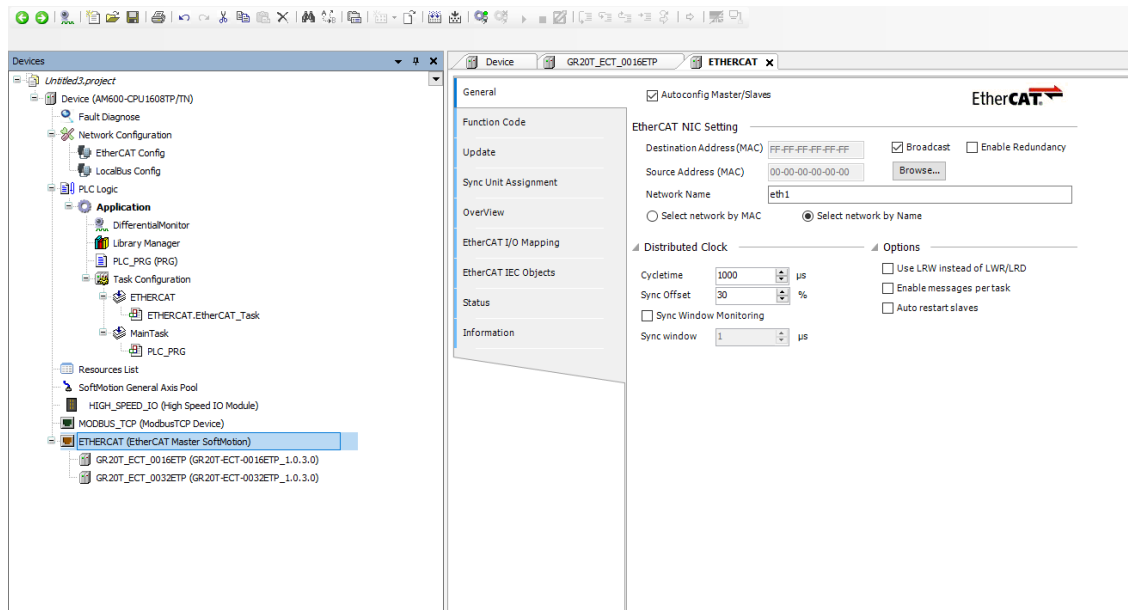

5. Double-click the EtherCAT slave that has been scanned and successfully added in the "Devices" pane. Then, click "EtherCAT I/O Mapping" on the GR20T-ECT-0016ETP tab to configure parameters and read the uploaded data of the module.

The following table describes functions of each variables when the DIO channel is configured as output.

Parameter	Description
DO Output CH	<p>Indicates the set value of the output channel.</p> <p>The 16 DO outputs of the GR20T-ECT-0016ETP module are controlled by Bit 0 to Bit 15 of the "DO Output Ch0".</p> <p>The first 16 DO outputs of the GR20T-ECT-0032ETP module are controlled by Bit 0 to Bit 15 of the "DO Output Ch0". The last 16 DO outputs are controlled by Bit 0 to Bit 15 of the "DO Output Ch1".</p>
DO stopmode after EtherCAT lost link	<p>Indicates the output status after disconnection of the output channel.</p> <p>1: Status maintained</p> <p>0: Output preset value</p> <p>The 16 DO outputs of the GR20T-ECT-0016ETP module are controlled by Bit 0 to Bit 15 of the "DO stopmode after EtherCAT lost link0".</p> <p>The first 16 DO outputs of the GR20T-ECT-0032ETP module are controlled by Bit 0 to Bit 15 of the "DO stopmode after EtherCAT lost link0". The last 16 DO outputs are controlled by Bit 0 to Bit 15 of the "DO stopmode after EtherCAT lost link1".</p>
DO stopvalue after EtherCAT lost link	<p>Indicates the output preset value after disconnection of the output channel.</p> <p>1: Output high level</p> <p>0: Output low level</p> <p>The 16 DO outputs of the GR20T-ECT-0016ETP module are controlled by Bit 0 to Bit 15 of the "DO stopvalue after EtherCAT lost link0".</p> <p>The first 16 DO outputs of the GR20T-ECT-0032ETP module are controlled by Bit 0 to Bit 15 of the "DO stopvalue after EtherCAT lost link0". The last 16 DO outputs are controlled by Bit 0 to Bit 15 of the "DO stopvalue after EtherCAT lost link1".</p>

The screenshot displays a software interface for configuring a device. On the left, a project tree shows the hierarchy: **Devices** > **GR20T_ECT_0016ETP** > **Application [main]** > **EtherCAT** > **EtherCAT I/O Mapping**. The main window is titled "Network Configuration" and shows the "General" tab for the device "GR20T_ECT_0016ETP".

The "EtherCAT I/O Mapping" table is as follows:

Variable	Mapping	Channel	Address	Type	Default Value	Current Value	Prepared Value	Unit	Description
DO	+	Digital output QHD-16bit	%QW1	UDINT	0				Digital output QHD-16bit
DO	+	DO stopmode after EtherCAT test link 0	%QW2	UDINT	0				DO stopmode after EtherCAT test link 0
DO	+	DO stopvalue after EtherCAT test link 0	%QW3	UDINT	0				DO stopvalue after EtherCAT test link 0
MO	+	Module Diagnosis information	%DW1	UDINT	0				Module Diagnosis information

5 Troubleshooting

When the ERR indicator is ON, it indicates that the module is faulty. In this case, a fault code is reported and can be accessed through the "Module Diagnosis Information" in the "EtherCAT I/O Mapping" interface of the module, as shown in the following figure.

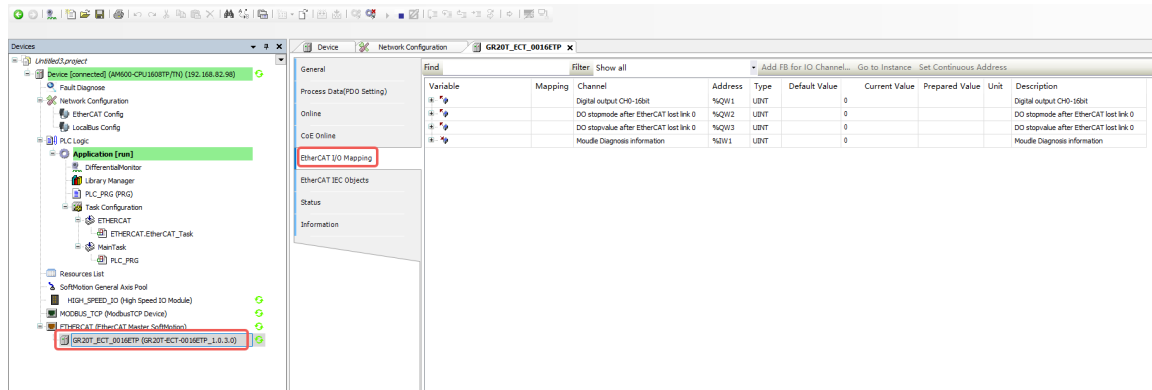

The following table describes the fault codes of the module.

Code	Description	Solution
0x0000	No fault	-
0x0001	24 VDC power supply not connected	Check whether the 24 VDC power supply of the module is connected properly.
0x0010	Output overcurrent occurred in the first 16 DO channels	Check whether the output connection is short-circuited.
0x0100	Output overcurrent occurred in the last 16 DO channels	Check whether the output connection is short-circuited.



Copyright © Shenzhen Inovance Technology Co., Ltd.

PS00018056A00

Shenzhen Inovance Technology Co., Ltd.

www.inovance.com

Suzhou Inovance Technology Co., Ltd.

www.inovance.com

Add.: Inovance Headquarters Tower, High-tech Industrial Park,
Guanlan Street, Longhua New District,
Shenzhen 518000, P.R. China

Tel: (0755) 2979 9595

Fax: (0755) 2961 9897

Add.: No. 52, Tian E Dang Road, Wuzhong District, 215104,
Suzhou City, Jiangsu Province, P.R. China

Tel: (0512) 6637 6666

Fax: (0512) 6285 6720